

Art. 91812

# TREK



Compatibile con  
veicoli 12/24V  
Compatible with  
12/24V vehicles



Protezione da corto circuito, surriscaldamento,  
sovraccarico e sovratensione  
Short circuit, overheat, overload and  
overvoltage protection



Fuse

Fusibile intelligente auto-rigenerante  
(non necessita sostituzione)  
Internal self-resetting fuse.  
(no need to replace it)



Cable

Lunghezza del cavo  
Cable length



Power

Ricarica veloce per tutti i dispositivi mobili  
Fast recharge for all mobile devices



Rainproof

Prese USB isolate. Ricarica il telefono anche  
quando piove  
Isolated USB sockets. Charge your phone  
even when it rains



5400 mA



IP66



## Optiline

LAMPA S.p.A.  
Via G. Rossa, 53/55,  
46019 Viadana (MN) ITALY  
Tel. +39 0375 820700  
UNI EN ISO 9001:2015  
Certified Company  
[www.optiline.it](http://www.optiline.it)

Garanzia / Warranty



Made in China

## IT Doppia presa USB completamente resistente alla pioggia

Permette di continuare a caricare il vostro dispositivo anche in condizioni atmosferiche avverse. 3 tipologie di fissaggio incluse: attacco per manubrio da 22-32mm; staffa di fissaggio con adesivo o viti; adattatore per attacchi Optiline. Cablaggio elettrico da 150cm. Fusibile intelligente auto-rigenerante (non necessita manutenzione). SMART CHIP: per una ricarica veloce e protetta. Protezione corto circuito, surriscaldamento, sovraccarico, sovratensione.

### Modalità di collegamento:

#### 1 Collegamento diretto sulla batteria.

Se non si utilizza il veicolo per diverso tempo potrebbe scaricare la batteria.

#### 2 Collegamento sotto la chiave dell'impianto elettrico del veicolo.

Collegare il cavo rosso (+) direttamente all'impianto elettrico del veicolo, ad esempio al cavo positivo del clacson o delle luci. In questo modo la presa USB sarà alimentata solo a chiave inserita e quadro acceso.

È sconsigliata l'installazione verticale per evitare lo stagnare dell'acqua all'interno delle prese USB.

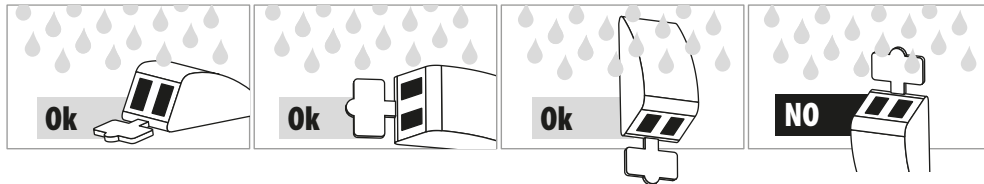

## DE Doppeltes USB-Ladegerät, vollständig regenfest

Ermöglicht das Aufladen Ihres Geräts auch bei schlechten Wetterbedingungen. 3 Befestigungsarten inklusive: Lenkerhalterung von 22-32mm; Befestigungsbügel mit Kleber oder Schrauben; Adapter für Optiline-Halterung. Intelligente selbstregenerierende Sicherung (muss nicht ausgetauscht werden). 150 cm lange elektrische Verkabelung. SMART CHIP: für sicheres und schnelles Aufladen. Kurzschluss-, Überhitzungs-, Überlast- und Überspannungsschutz.

### Verbindungsmethode:

**1 Direkter Anschluss an die Batterie.** Wenn Sie das Fahrzeug längere Zeit nicht benutzen, kann die Batterie entladen werden.

#### 2 Anschluss unter dem Bordnetzschlüssel.

Schließen Sie das rote (+) Kabel direkt an das Bordnetz des Fahrzeugs an, z. B. die positive Hupe oder das Lichtkabel. Auf diese Weise wird die USB-Buchse nur mit eingestecktem Schlüssel und eingeschaltetem Bedienfeld mit Strom versorgt.

Eine vertikale Installation wird nicht empfohlen, um zu vermeiden, dass das Wasser in den USB-Anschlüssen stagniert.

## EN Double USB charger fully rainproof

Allows to charge your device even in bad weather conditions. 3 types of fixing included: handlebar mount from 22-32 mm; fixing bracket with adhesive or screws; adapter for Optiline mount. Intelligent self-regenerating fuse (does not require replacement). 150cm electrical wiring. SMART CHIP: for a safe and fast recharge. Short circuit, overhear, overload and overvoltage protection.

### Connection method:

#### 1 Direct connection to the battery.

If you do not use the vehicle for a long time it may drain the battery.

#### 2 Connection under the vehicle's electrical system key.

Connect the red (+) cable directly to the vehicle's electrical system, such as the positive horn or light cable. In this way the USB socket will be powered only with the key inserted and the panel turned on.

We don't recommend the vertical installation in order to avoid the water to stagnate inside the USB ports.

## FR FR Double chargeur USB entièrement étanche à la pluie

Vous pouvez charger votre dispositif sous la pluie. 3 types de fixation inclus : support de guidon de 22 à 32 mm ; support de fixation avec adhésif ou vis ; adaptateur pour montage Optiline. SMART CHIP: pour charger votre dispositif de manière vite et sûre. Câblage électrique 150cm. Fusible intelligent auto-régénérant: (ne nécessite pas de remplacement). Protection contre les courts-circuits, les surchauffes, les surcharges et les surtensions.

### Méthode de connexion:

#### 1 Connexion directe à la batterie.

Si vous n'utilisez pas le véhicule pendant une longue période, la batterie risque de se vider.

#### 2 Connexion sous la clé du système électrique du véhicule.

Connectez le câble rouge (+) directement au système électrique du véhicule, tel que le câble du klaxon ou du voyant. De cette façon, la prise USB sera alimentée uniquement avec la clé insérée et le panneau allumé.

L'installation verticale n'est pas recommandée pour éviter la stagnation d'eau à l'intérieur des prises USB.

## ES Doble toma USB resistente a la lluvia

Le permite continuar la recarga de su dispositivo incluso bajo la lluvia. 3 tipos de fijación incluidos: soporte de manillar de 22-32 mm; soporte de fijación con adhesivo o tornillos; adaptador para montura Optiline. Fusiblede regeneración automática inteligente (no requiere reemplazo). SMART CHIP: para una recarga rápida y protegida. Cableado eléctrico de 150cm. Cortocircuito, sobrecalentamiento, sobrecarga y protección contra sobretensiones.

### Método de conexión:

#### 1 Conexión directa a la batería.

Si no usa el vehículo por mucho tiempo, puede agotar la batería.

#### 2 Conexión bajo la llave del sistema eléctrico del vehículo.

Conecte el cable rojo (+) directamente al sistema eléctrico del vehículo, como la bocina positiva o el cable de luz. De esta manera, la toma USB se alimentará solo con la llave insertada y el panel encendido.

No se recomienda la instalación vertical para evitar el estancamiento del agua dentro de los enchufes USB.

## NL Dubbele USB-aansluiting volledig bestand tegen regen

Hiermee kunt u uw apparaat blijven opladen, zelfs in ongunstige weersomstandigheden. 3 soorten bevestiging inbegrepen: stuurbevestiging van 22-32 mm; bevestigingsbeugel met lijm of schroeven; adapter voor Optiline montage. 150cm elektrische bedrading. Intelligente zelfherstellende zekering (onderhoudsvrij). SMART CHIP: voor snel en beschermd opladen. Kortsluiting, oververhitting, overbelasting, overspanningsbeveiliging

### Verbindingsmethode:

#### 1 Directe aansluiting op de accu.

Als u het voertuig lange tijd niet gebruikt, kan de accu leeglopen.

#### 2 Aansluiting onder de sleutel van het elektrische systeem van het voertuig.

Sluit de rode (+) kabel rechtstreeks aan op het elektrische systeem van het voertuig, zoals de positieve claxon- of lichtkabel. Op deze manier wordt de USB-aansluiting alleen gevoed als de sleutel is geplaatst en het paneel is ingeschakeld.

We raden de verticale installatie niet aan om te voorkomen dat het water in de USB-poorten stagneert.

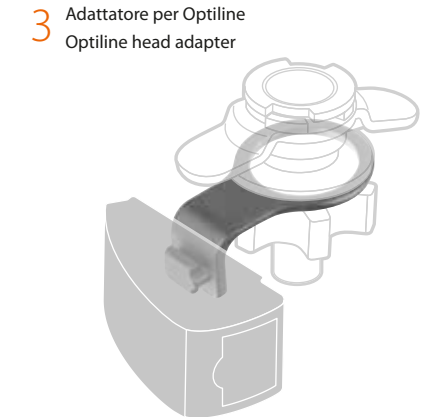
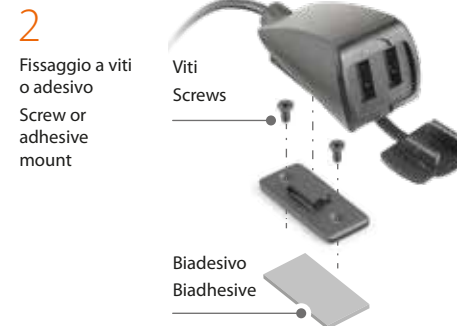

 Optiline

Video di installazione  
Installation video

